

Table Tops and Bases

Tops



<p>PL</p> <p>PD</p> 	<p>Common Top - 1 leading Edge</p> <p>Spec. T-Common - "PD,PL"</p> <p>PD - 12" to 30"</p> <p>PL = 30" to 108"</p> <p>Note: This unit is used to bridge across two or more base storage units.</p>
<p>PL</p> <p>PD</p> 	<p>Rectangular Top</p> <p>Spec. T-Rect - "PD,PL"</p> <p>Maximum Dimension per section = <u>60</u> x 96 or <u>48</u> x 108</p>
	<p>Round Top</p> <p>Spec. T-Round - "D"</p> <p>D = Diameter</p> <p>Maximum Diameter = 60"</p>
<p>PL</p> <p>PD</p> 	<p>Race Track Top</p> <p>Spec. T-Race - "PD,PL"</p> <p>Maximum Dimension per section = <u>60</u> x 96 or <u>48</u> x 108</p>
<p>PL</p> <p>PD</p> 	<p>Boat Top</p> <p>Spec. T-Boat - "PD,PL"</p> <p>Maximum Dimension per section = <u>60</u> x 96 or <u>48</u> x 108</p>
<p>PL</p> <p>PD</p> 	<p>Arched End Top</p> <p>Spec. T-ArchE - "PD,PL"</p> <p>Maximum Dimension per section = <u>60</u> x 96 or <u>48</u> x 108</p>

Table Tops and Bases - (cont'd)

Metal Bases



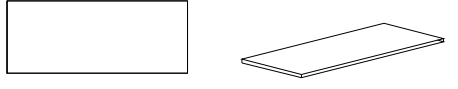
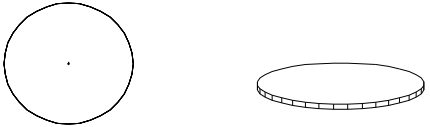

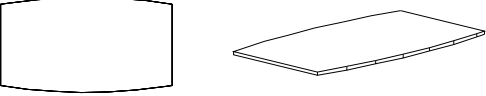
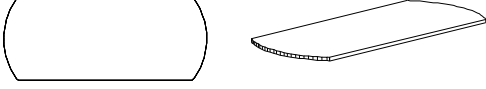



TRT Series Metal Bases:		<u>Finishes:</u> "Ch" = Chrome "SCh" = Satin Chrome "BrCh" = Brushed Chrome "PC" = Black Powder Coat	
		<u>Spec. Model Number</u> PST-"Finish"-1000 (1" Diameter Post Leg) PST-"Finish"-1250 (1.25" Diameter Post Leg) PST-"Finish"-1500 (1.5" Diameter Post Leg) PST-"Finish"-2000 (2" Diameter Post Leg) PST-"Finish"-2500 (2.5" Diameter Post Leg) PST-"Finish"-3000 (3" Diameter Post Leg) PST-"Finish"-4000 (4" Diameter Post Leg) PST-"Finish"-5000 (5" Diameter Post Leg) PST-"Finish"-6000 (6" Diameter Post Leg)	
		<u>Spec. Model Number</u> TRT-"Finish"-2424 TRT-"Finish"-3030 TRT-"Finish"-3636 TRT-"Finish"-4242	<u>Max. Top Size</u> (32 x 32) (42 x 42) (48 x 48) (54 x 54)
		<u>Spec. Model Number</u> TRT-"Finish"-2430 TRT-"Finish"-2436 TRT-"Finish"-3036	<u>Max. Top Size</u> (30 x 42) (30 x 48) (42 x 48)
		<u>Spec. Model Number</u> TRT-"Finish"-2400 TRT-"Finish"-3000 TRT-"Finish"-3600	<u>Max. Top Size</u> (30 x 84 - 2 Required) (40 x 84 - 2 Required) (48 x 96 - 2 Required)
		<u>Spec. Model Number</u> TRT-"Finish"-3602 TRT-"Finish"-4202	<u>Max. Top Size</u> (54 x 96 - 2 Required) (60 x 96 - 2 Required)
		<u>Spec. Model Number</u> TRT-"Finish"-2412 TRT-"Finish"-3015 TRT-"Finish"-3618	<u>Max. Top Size</u> (30 x 84 or 54D - 2 Required) (42 x 96 or 60D - 2 Required) (48 x 108 or 72D - 2 Required)

Table Tops and Bases - (cont'd)

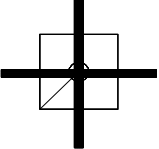
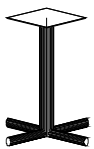
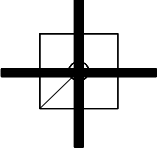
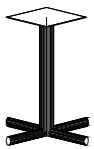
Metal Bases

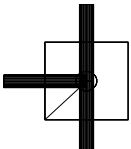

HFL Series Metal Bases:		Finishes:	
		"Ch" = Chrome	"BrCh" = Brushed Chrome
		"SCh" = Satin Chrome	"PC" = Black Powder Coat
 	<u>Spec. Model Number</u>	<u>Max. Top Size</u>	
	HFL-"Finish"-2424	(32 x 32)	
	HFL-"Finish"-3030	(42 x 42)	
	HFL-"Finish"-3636	(48 x 48)	
 	<u>Spec. Model Number</u>	<u>Max. Top Size</u>	
	HFL-"Finish"-2400	(30 x 84 - 2 Required)	
	HFL-"Finish"-3000	(40 x 84 - 2 Required)	
	HFL-"Finish"-3600	(48 x 96 - 2 Required)	
 	<u>Spec. Model Number</u>	<u>Max. Top Size</u>	
	HFL-"Finish"-3602	(54 x 96 - 2 Required)	
	HFL-"Finish"-4202	(60 x 96 - 2 Required)	
 	<u>Spec. Model Number</u>	<u>Max. Top Size</u>	
	HFL-"Finish"-2412	(30 x 84 or 54D - 2 Required)	
	HFL-"Finish"-3015	(42 x 96 or 60D - 2 Required)	
	HFL-"Finish"-3618	(48 x 108 or 72D - 2 Required)	

Table Tops and Bases - (cont'd)

Wood Bases



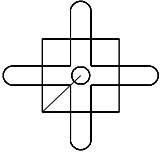
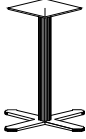
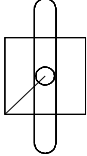
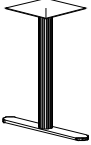

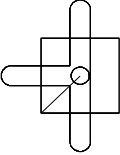
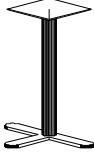
	<p>Rectangular Base</p> <p>Spec. RectB-16 16" Base RectB-20 20" Base RectB-24 24" Base RectB-28 28" Base</p>
	<p>Panel Base</p> <p>Spec. PB-"PD,PL"</p> <p>Sizes based on Top Size: PD = Top Width PL = Top Length</p>
	<p>X Base</p> <p>Spec. XB-16 16" x 16" Base XB-20 20" x 20" Base XB-24 24" x 24" Base XB-28 28" x 28" Base</p>
	<p>1/2 Drum Base</p> <p>Spec. DrumB1/2-16 16" Diameter 1/2 Drum DrumB1/2-20 20" Diameter 1/2 Drum DrumB1/2-24 24" Diameter 1/2 Drum DrumB1/2-28 20" Diameter 1/2 Drum</p>
	<p>Drum Base</p> <p>Spec. DrumB-16 16" Diameter Drum DrumB-20 20" Diameter Drum DrumB-24 24" Diameter Drum DrumB-28 28" Diameter Drum</p>
	<p>Arch Base - Fixed Panels</p> <p>Spec. ArchB-FP-20 20" Base ArchB-FP-24 24" Base ArchB-FP-28 28" Base ArchB-FP-34 34" Base</p> <p>Arch Base - c/w 1 Removable Access Panel</p> <p>Spec. ArchB-AccP-20 20" Base ArchB-AccP-24 24" Base ArchB-AccP-28 28" Base ArchB-AccP-34 34" Base</p>

Table Tops and Bases - (cont'd)

Occasional Tables

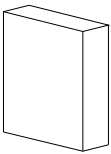
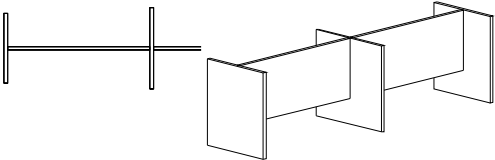
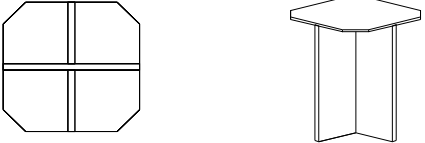
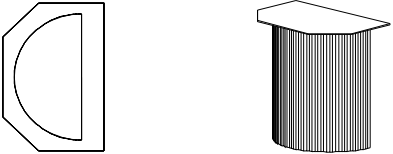
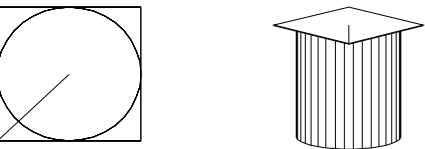
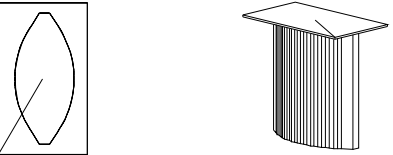
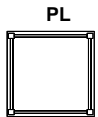
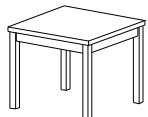
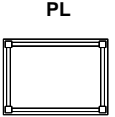
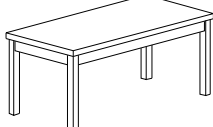
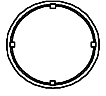

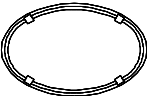
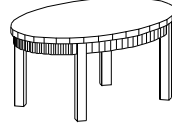
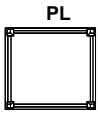
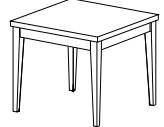
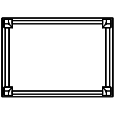
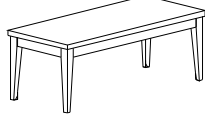
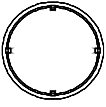
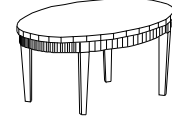
				Square Leg
PD		PH		Spec. OTSL -S- " PD,PL-PH" PD= 18, 24, 30, 36,42 PL= 18, 24, 30, 36, 42 PH= 16, 21, 29
PD		PH		Spec. OTSL -S- " PD,PL-PH" PD= 12, 18, 24, 30 PL= 24, 30, 36, 42, 48 PH= 16, 21, 29
		PH		Spec. OTSL -R- " Diam.-PH" Diam = 24, 30, 36, 42 PH= 16, 21, 29
PD		PH		Spec. OTSL -O- " size - PH" size = 18 x 24, 24 x 36, 24 x 42, 30 x 48 PH= 16, 21, 29
				Tapered Leg
PD		PH		Spec. OTTL -S- " PD,PL-PH" PD= 18, 24, 30, 36,42 PL= 18, 24, 30, 36, 42 PH= 16, 21, 29
PD		PH		Spec. OTTL -S- " PD,PL-PH" PD= 12, 18, 24, 30 PL= 24, 30, 36, 42, 48 PH= 16, 21, 29
		PH		Spec. OTTL -R- " Diam.-PH" Diam = 24, 30, 36, 42 PH= 16, 21, 29
PD		PH		Spec. OTTL -O- " size - PH" size = 18 x 24, 24 x 36, 24 x 42, 30 x 48 PH= 16, 21, 29